

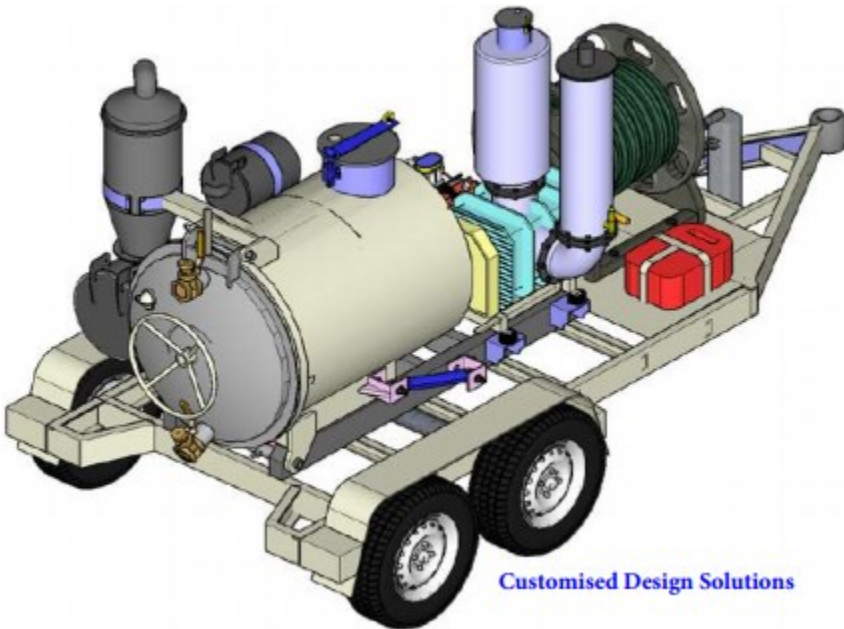

SOUTH PACIFIC VACUUMS LTD

COMMERCIAL AND INDUSTRIAL CLEANING EQUIPMENT

VACUUM RECOVERY MADE EASY SR-1000 | SR-750 | SR-400



Customised Design Solutions

	SR-1000	SR-750	SR-400
Empty Weight	650 kg (Tank only)	600 kg (Tank only)	500 kg (Tank only)
Overall Dimensions (LxWxH)	1750 x 1450 x 1740 mm	1650 x 1450 x 1740 mm	1600 x 1350 x 1550 mm
Tank Capacity	1000L	750L	400L
Filtration	3 stage filtration with cyclone separator	3 stage filtration with cyclone separator	3 stage filtration with cyclone separator
Tank tilt type	Twin hydraulic cylinders	Twin hydraulic cylinders	Fixed frame at angle
Door opening type	Hydraulic	Hydraulic	Manual operated
	3-Stage cyclonic filtration	3-Stage cyclonic filtration	3-Stage cyclonic filtration
	Vacuum filter - Inline safety filter housing - 4"	Vacuum filter - Inline safety filter housing - 4"	Vacuum filter - Inline safety filter housing - 3"/ 4"
	Primary high level shutoff - 4"	Primary high level shutoff - 4"	Primary high level shutoff - 3"/ 4"
	Secondary shutoff with cyclone - 4"	Secondary shutoff with cyclone - 4"	Secondary shutoff with cyclone - 3"/ 4"
	Knock out box / Grit Rider	Knock out box / Grit Rider	Knock out box / Grit Rider
	EnduroVac package	Enduro Ute-Vac package	
Power pack	V-twin Kohler/Honda Petrol Engine or Kohler Diesel Option	V-twin Kohler/Honda Petrol Engine	
Vacuum System	Positive Displacement Tri Lobe Blower operating	Positive Displacement Tri Lobe Blower	
Gauges	Vacuum pressure and fuel level	Vacuum pressure and fuel level	
Fuel Tank Capacity	25L Petrol / 45L Diesel	25L Petrol	
Silencers	Inlet and outlet Silencers	Inlet and outlet Silencers	
Valves	High Vacuum Safety Relief valves	High Vacuum Safety Relief valves	
Safety filter	Inline Vacuum producer safety filter	Inline Vacuum producer safety filter	
	Tri Belt Drive	Tri belt Drive	



Power pack
Petrol or Diesel Engine

Vacuum System
Positive Displacement Tri Lobe Blower operating at up to 15Hg



+64 9 5202030

+64 27 5398081

paul@spv.nz

www.spv.nz

