

Head

Assembly Part No: 2663

POS	NUMBER	DESCRIPTION	#
1	VP00466 AUS	ELECTRIC CORD 3X1 (AUS)	1
2	VP00138	CABLE SLEEVE	1
3	VP00139	CABLE CLAMP	1
4	VP01006	SCREW 5X20	2
5	VP00140	TERMINAL BOARD 3 POLES	1
6	VP02589	CABLE HOOK	1
7	VP01026	SCREW 5X30	4
8	VP02588	HANDLE	1
9	VP01050	SCREW 5X35	2
10	VP01050	SCREW 5X35	2
11	VP02716	TOP COVER W/ADD SOCKET	1
12	VP00326	ANTISPLASH SWITCH	1
13	VP01006	SCREW 5X20	4
14	VP03937	FILTER MTP/65 H=15 D.95	1
15	VP01050	SCREW 5X35	6
16	VP02738	MOTOR COVER	1
17	VP03969	WASHER H8 D85X65	1
18	VP00310	PLASTIC RING FOR MOTOR 1200 W.	1
19	VP03900	FOAM FILTER	1
20	VP02627	SCREW 5X40	6
21	VP01006	SCREW 5X20	4
22	VP02591	MOTOR FASTENER	1
23	VP03901	MOTOR GASKET	1
24	VP03973 S	MOTOR 1000W 240/250V 50/60HZ = AU	1
24	VP03891 S	MOTOR 1000W 220-240V 50/60HZ = NZ	1
25	VP03901	MOTOR GASKET	1
26	VP03866	WASHER MTP 65MM 18D 230X145	1
27	VP01189 G	MOTOR BASE W/GASKET	1
*	VP01101	CONNECTING WIRES	4
*	VP01102	CONNECTING WIRES	1
*	VP01106	CLIP	3
*	VP01103	FASTENER	2
43	VP02184	ADD.SOCKET PROTECTION	1
44	VP00098	ADDITIONAL SOCKET SCREW	1
45	VP01044	SCREW M 3X10	2
46	VP01046	NUT 3 MA	2



Filter

Assembly Part No: 4244

POS	NUMBER	DESCRIPTION	#
1	VP03706	PLASTIC SLEEVE D.8	4
2	VP03724	SCREW 5X25	4
3	VP02823-1	HIGHER ANTIFOAM BODY	1
4	VP03138	FILTER NET 0,4 D.90 H=45	1
5	VP02676 C/G	HIGHER FLOAT	1
6	VP00123	FILTER RING 300	1
7	VP02860	CONICAL POLYESTER.FILTER 300	1
8	VP02859	CONICAL BASKET 300	1

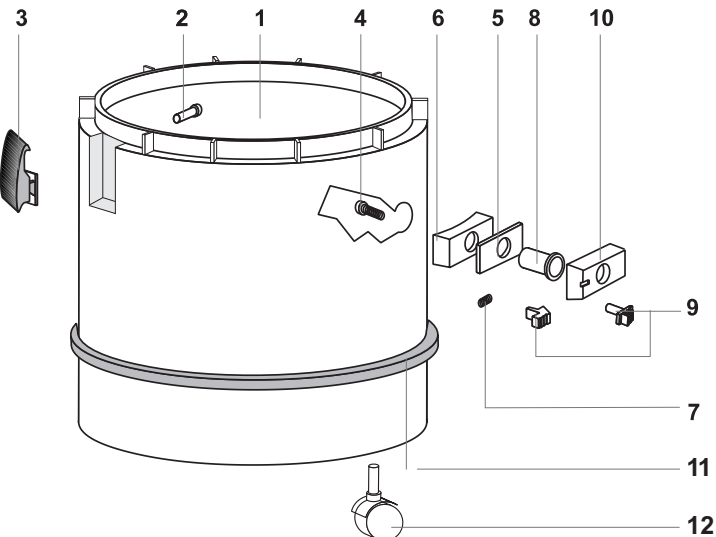
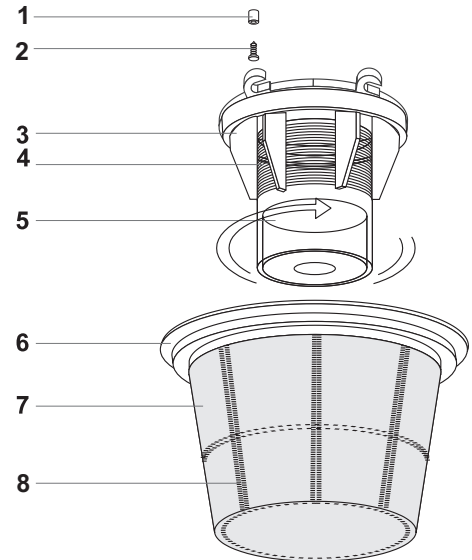

Tank

Assembly Part No: 2644

POS	NUMBER	DESCRIPTION	#
1	VP02643	TANK	1
2	VP01300	RIVET 5X24,5	4
3	VP01847/S	HOOK PLASTIC COMPLETE	2
4	VP01026	SCREW 5X30	4
5	VP02846	GASKET D.38	1
6	VP02586	GASKET R 205	1
7	VP02608	SPRING SPIRAL 99	1
8	VP02593	DEFLECTOR	1
9	VP02594	INLET BUTTON	1
10	VP02583	INLET 99	1
11	VP02630	ANTI-SHOCK BAND	1
12	VP00558	TROLLEY WHEEL BOX	4